

S-DISPENSER (SLP-D)

Automatic Gel & Soap Dispenser

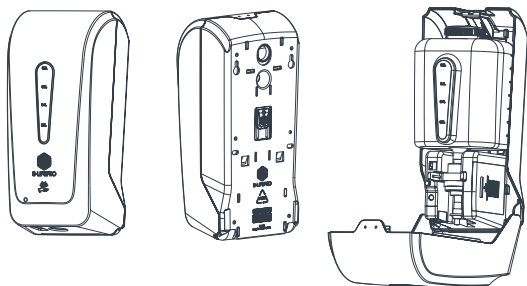

Product dimensions
129L x 106W x 273H mm

Characteristics

MADE IN PORTUGAL

1000ml capacity
Reusable reservoir.

Easy to use
Hygienic and easily disinfectable.

Security lock
Opens only with the key.

Adjustable discharger
Choose drip or jet and 1 or 2 doses (1ml each).

Modern Design
Fits to all environments. Possibility to personalize with company logo.

Touchless
Motion activated by magnet.

Battery powered
1.5V AA (4 pack) batteries – not included.

Removable pump and reservoir
Allows cleaning of single parts.

Components

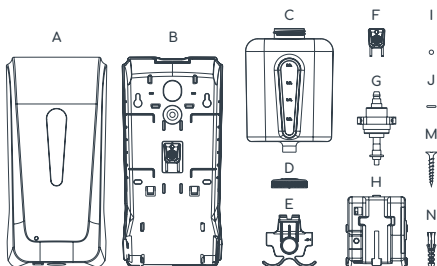

A	Front	G	Pump
B	Back	H	Battery control box
C	Reservoir	I	Magnet – the dispenser only works when activated by the magnet
D	Reservoir lid	J	O-ring
E	Security lock	L	4x Screws
F	Key	M	4x Screw anchors

Storage and Cleaning

It can be stored and moved in its original packaging at room temperature (0°C to 30°C). Can be stored in dark environments for up to 3 years. **Do not store in places where directly exposed to light and heat.** Clean with warm water, soap and a soft cloth or with a non-abrasive disinfectant solution. **Do not use solvents or abrasives.**

If Damaged

If the Dispenser are pitted, scratched or damaged, they must be replaced with an original equivalent.

Produced by

PLASTIMAGO Lda. | Estrada de Leiria, N° 208
Embra 2430-091 | Marinha Grande, Portugal

S-DISPENSER (SLP-D)

Automatic Gel & Soap Dispenser

Installation Instructions

1.

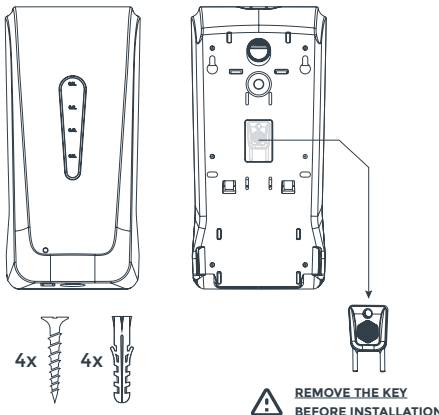

4x
4x

REMOVE THE KEY BEFORE INSTALLATION

Packaging list.

2.

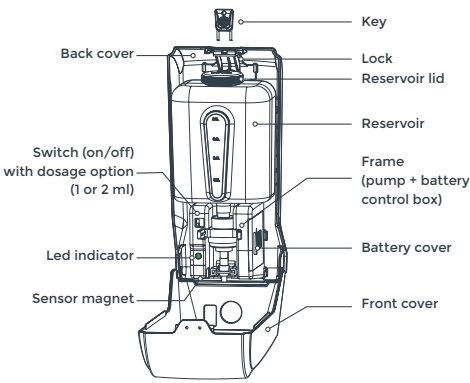

Key
Lock
Reservoir lid
Reservoir
Frame (pump + battery control box)
Battery cover
Front cover
Sensor magnet
Led indicator
Switch (on/off) with dosage option (1 or 2 ml)
Back cover

Part name.

3.

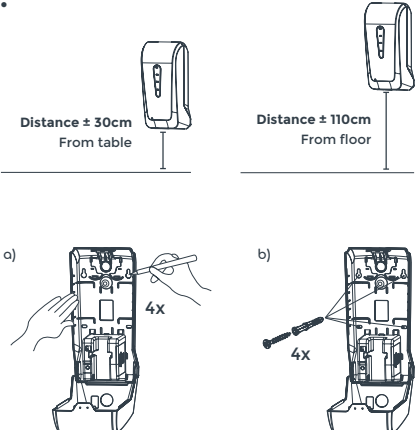

Distance \pm 30cm
From table

Distance \pm 110cm
From floor

a) 4x

b) 4x

Install the dispenser on the recommended height from floor or table:

- With a pencil, mark the place to put drill holes in the wall;
- Place the anchors and screws.

4.

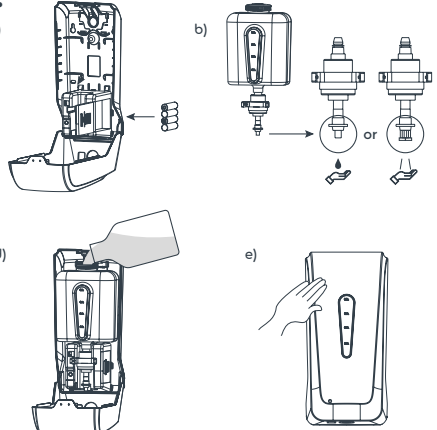

a)

b)

c)

d)

e)

Make the dispenser functional:

- Put the batteries;
- Choose to use drip or jet;
- Place the reservoir inside the box;
- Fill the reservoir with liquid or gel;
- Close the front cover.